

DN20 C&B Mains Valve Assembly Instructions

1.

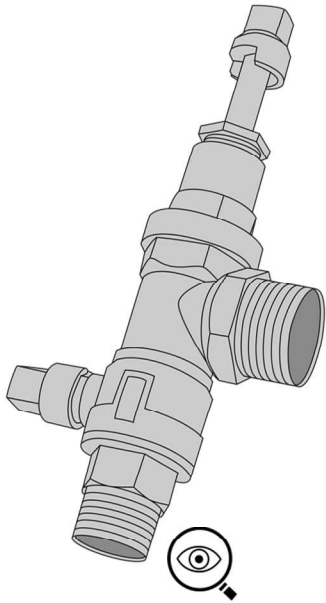

Inspect Valve thread for debris as foreign matter can damage and compromise seal.

2.

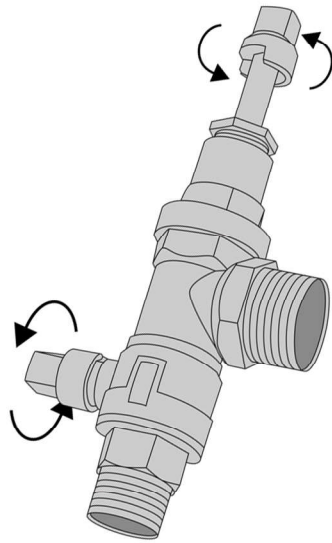

Test Operation of valve by opening & closing.

3.

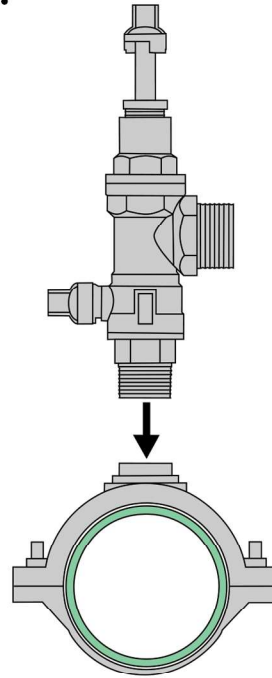

Fit appropriate ferrule to tapping band.

4.

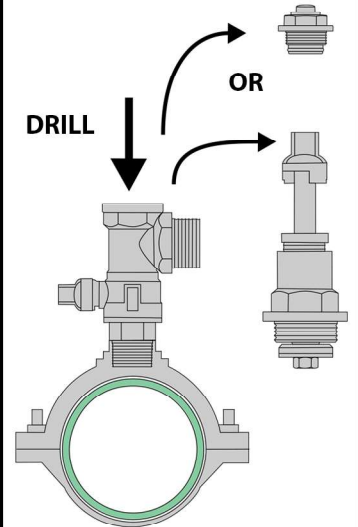

Remove bonnet (or cap) and open the ball valve. Screw tapping drill into ferrule with appropriate drill piece.

5.

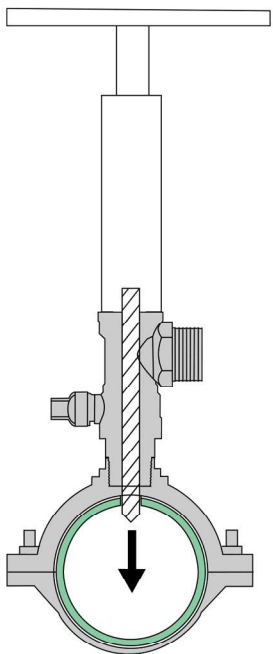

Use drill according to manufacturer's manual as to penetrate pipe for live services.

6.

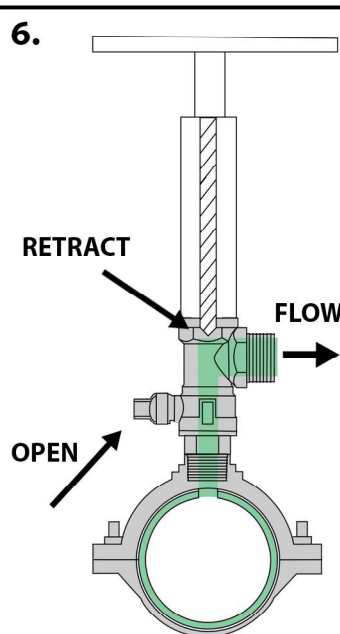

Retract drill from pipe to clear ball valve section, then allow for water to pass through the outlet by opening the ball valve.

7.

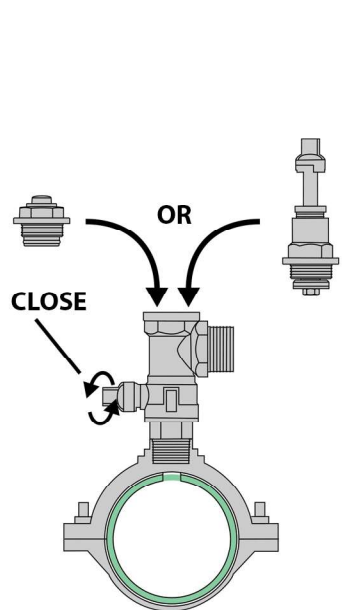

Close ball Valve and re-assemble bonnet (or cap) to ferrule body.

8.

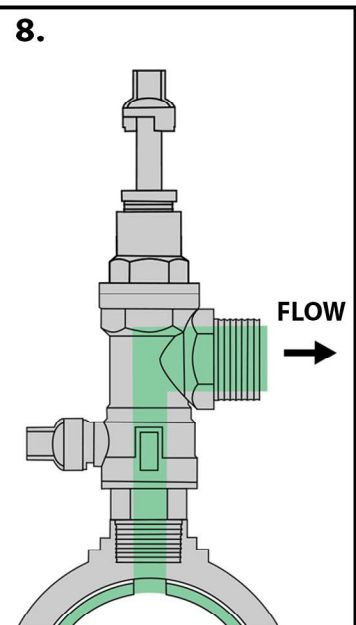

Connect appropriate pipe to ferrule according to relevant standard and open bonnet to allow full flow.