

Appendix D.

Mechanical Compression Unions for Polyethylene Pipe

Valves: QC7094, ZC7094, NC7094, NC7095,
 QC7095, ZC7095, C2532, C7093.
Fittings: ZC7079, QC7079, C7078, PS4000.
Dual Check Valves: ZC707925, QC707925,
 C707825 Meter Housing

1.

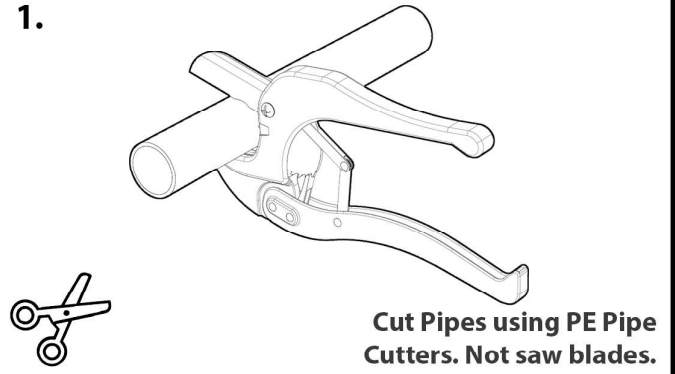

2.

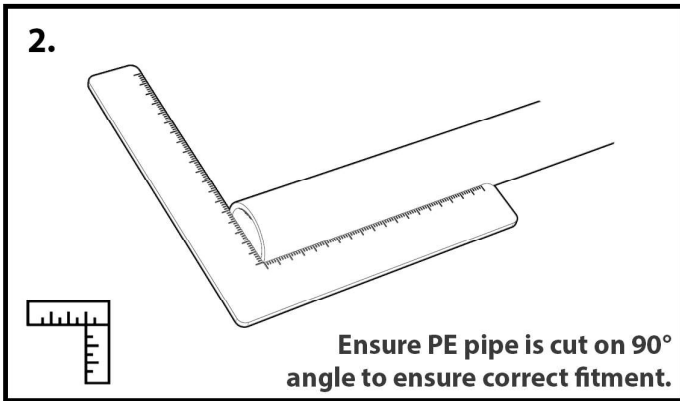

3.

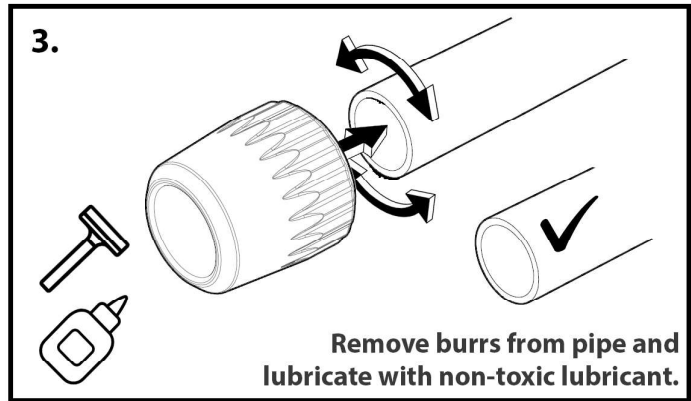

4.

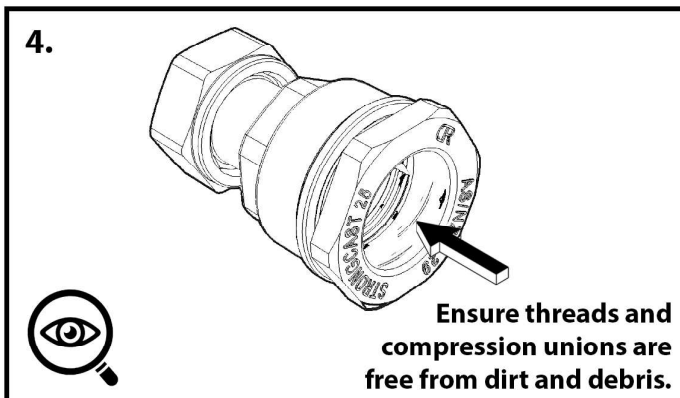

5.

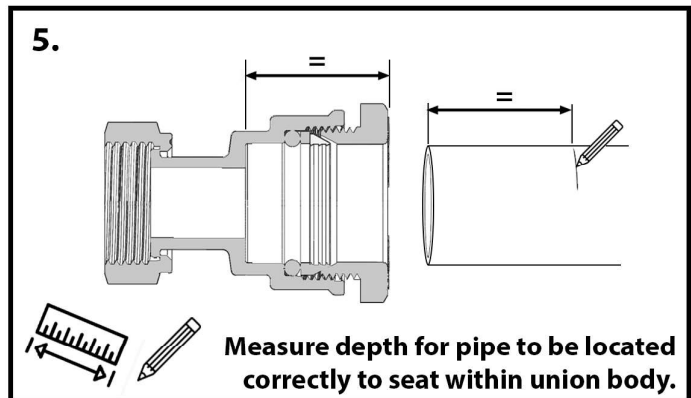

6.

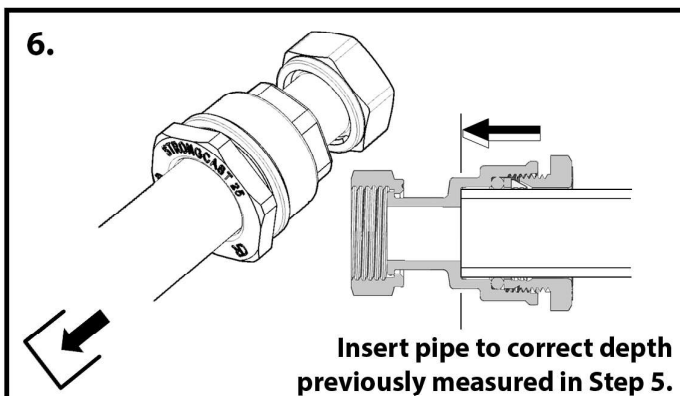

7.

